

SEARS

Owner's Manual

Model No.
680.84973

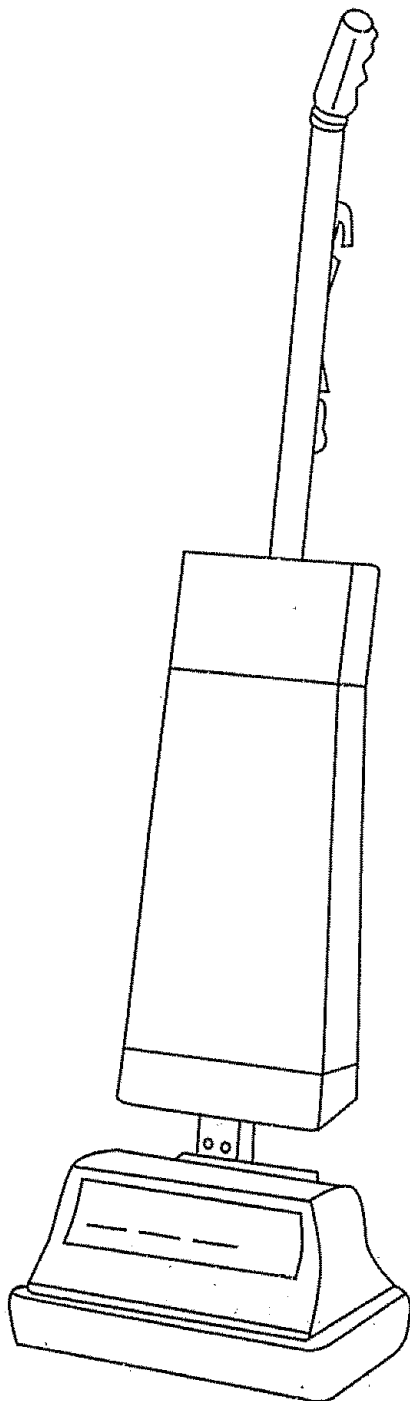

**Assembly
Operation
Repair Parts**

Save This Manual For Future Reference
CAUTION: Read rules for safe operation and instructions carefully

Sold by SEARS, ROEBUCK AND CO., Chicago, IL 60179 U.S.A

SHAMPOOER / POLISHER

IMPORTANT SAFETY INSTRUCTIONS

This Rug shampooer/floor polisher is for household use only.

When using electrical Rug shampooer/floor polisher, basic precautions should be followed. Including the following

READ ALL INSTRUCTIONS BEFORE USING THIS APPLIANCE

WARNING

To reduce risk of fire, electric shock, or injury

- DO NOT USE FLAMABLE OR COMBUSTIBLE LIQUIDS, SUCH AS GASOLINE, OR USE IN AREAS WHERE THEY MAY BE PRESENT.
- Do not leave this appliance when plugged in.
- To reduce the risk of electric shock-Use indoors only.
- This appliance is provided with double insulated. Use only identical replacements parts. See instructions for servicing of double-insulated appliances.
- Do not immerse. To reduce risk of electric shock - Use only carpet moistened by cleaning process.
- to reduce the risk of fire, use only commercially available floor cleaners and waxes intended for machine application.
- Unplug from outlet when not in use and before servicing.
- Do not allow to be used as a toy. Close attention is necessary when used by or near children.
- Use only as described in this manual. Use only manufacturer's recommended attachments.
- Do not use with damage cord or plug. If appliance is not working, as it should, have been dropped, damage, left outdoors dropped into water, return it to service center before using.
- Do not pull or carry by cord, use cord as a handle, close a door on cord, or pull a cord around sharp edges or corners. Do not run appliance over cord, keep cord away from heated surfaces.
- Do not unplug by pulling on cord. To unplug, grasp the plug, not the cord.
- Do not handle plug with wet hands.
- Do not put any object into openings. Do not use with any openings blocked; keep free of dust, lint, hair, and anything that may reduce airflow.
- Keep hair, loose clothing, fingers, and all parts of body away from opening and moving parts.
- Do not attach or remove brushes with electric cord plugged in.
- Turn-off before unplugging.
- Use extra care when cleaning on stairs.
- Never fill dispenser without removing it from the appliance.
- Never turn the appliance on with the handle in the upright position. Make sure handle is in operating position.
- Disassembly of this unit can be hazardous.
- Do not leave appliance turned on when it is not in motion.

SAVE THESE INSTRUCTIONS

SERVICING OF DOUBLE-INSULATED APPLIANCES

A double-insulated appliance is marked with one or more of the following: The words "DOUBLE INSULATION" or "DOUBLE INSULATED" or the double insulation symbol (square within a square.)



In a double-insulated appliance, two systems of insulation are provided instead of grounding. No grounding means is provided on a double-insulated appliance; nor should a means for grounding be able to the appliance, Servicing a double-insulated appliance requires extreme care and knowledge of the system, and should be done only by qualified service personnel. Replacements parts for a double-insulated appliance must be identical to the part they replace.

Polarization Instructions:

To reduce the risk of electric shock, this appliance has a polarized plug (one blade is wider than the other). This plug will fit in a polarized outlet only one way. If the plug does not fit fully in the outlet, reverse the plug. If still does not fit, contact a qualified electrician to install the proper outlet. Do not change the plug in any way.

SEARS

Owner's Manual

Dear Homemaker:

You have just invested in a fine Kenmore Rug Shampooer-Floor Polisher.

Before using your new Kenmore machine, please pause for a moment and carefully read this booklet, which contains instructions on how to operate and care for your machine.

Specific instructions are given on rug shampooing, scrubbing, polishing, attaching and cleaning brushes, etc. This will help you to obtain the best performance and avoid unnecessary service expense for conditions beyond our control.

FULL ONE-YEAR WARRANTY

When used for private household purposes, if within one year from the date of purchase, this Shampooer/Polisher fails due to defects in material or workmanship, RETURN IT TO THE NEAREST SEARS SERVICE CENTER IN THE UNITED STATES, and Sears will repair it free of charge.

This warranty gives you specific legal rights, and you may also have other rights, which vary from state to state.

Sears, Roebuck and Co., Dept. 698/731A, Sears Tower, Chicago, IL 60684

WHERE TO FIND IT

PAGE

Warranty	3
Assembly	4
Dispenser	5
Operation	6-7
Parts List	8-11
Accessories, Service	12

DO NOT PLUG IN ELECTRIC CORD UNTIL BRUSHES OR OTHER ACCESORIES HAVE BEEN ATTACHED AND SWITCH HAS BEEN PLACED IN THE "OFF" POSITION.

**HANDLE,
SWITCH BOX AND CORD**

1. Place lower handle tube (Fig. 1) into handle tube socket "A" (Fig. 2). Fasten using bolt "B" and internally threaded nut "C" (Fig. 3) provided in the hardware package. If the handle tube is difficult to assemble (tight), insert blade of screwdriver into slot (Fig. 4) at rear of handle tube socket and twist screwdriver gently while inserting handle tube.

2. Place upper half handle tube (Fig. 1) over lower half. Align holes and fasten with remaining bolt "B" and internally threaded nut "C".

3. Attach switch box to rear of upper handle tube. Place switch box tab (no hole) into rectangular hole (Fig. 5). Position box against handle tube. Fasten using the small screw provided in the hardware package. **DO NOT OVERTIGHTEN.**

4. The motor cord, which goes from the switch box to the bottom of the unit, is attached in two (2) locations behind the dispenser at top and bottom. The upper part of the motor cord is snapped into place alongside the upper cord hook on the dispenser top (Fig 6).

The lower part of the motor cord is snapped into place between the two lower cord hooks. They are located on the dispenser base (Fig. 7).

5. Attach lower plastic hose to rear of unit by inserting the fitting on the end of hose into the hole located midway at rear of unit (Fig. 8).

6. The electric cord is wound around cord hooks as illustrated in (Fig. 9).

Note: All moving parts requiring lubrication have been permanently lubricated at the factory.

ASSEMBLY INSTRUCTIONS

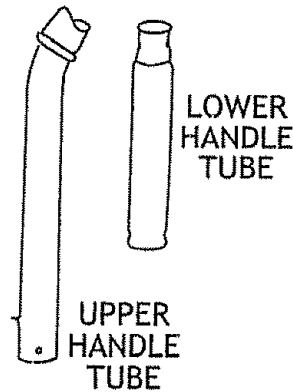

FIG. 1

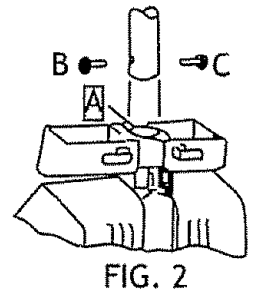

FIG. 2

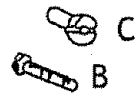

FIG. 3

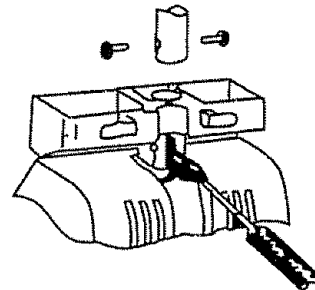

FIG. 4

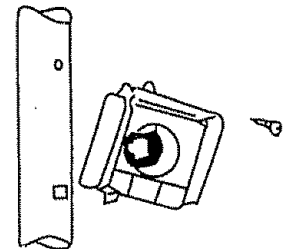

FIG. 5

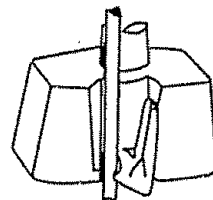

FIG. 6

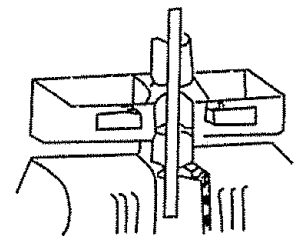

FIG. 7

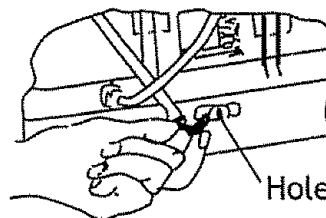

FIG. 8

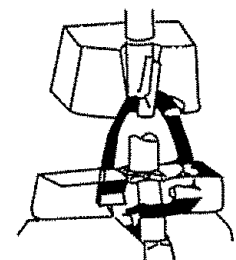

FIG. 9

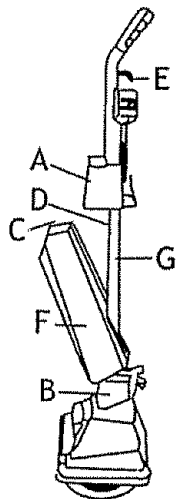

FIG. 10

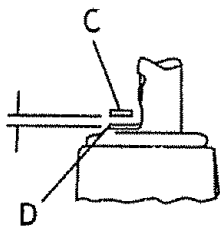

FIG. 11

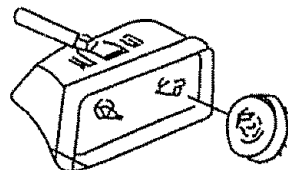

FIG. 12

DISPENSER

1. Raise dispenser top "A" (Fig. 10). Position dispenser "F" in base "B".
2. Press top dispenser firmly against the handle tube "G" Valve stem "C" must be above valve lifter "D" (Fig. 11).
3. Slide dispenser top "A" down so that it engages the dispenser and holds it securely in position.

To dispense the liquid, pull trigger "E" momentarily and intermittently. Liquid will flow as long as the trigger is raised.

Note: If the dispenser fails to discharge liquid when the trigger is raised all the way, tilt the dispenser away from the handle tube. Take a pair of long-nosed pliers and grasp the valve lifter "D".

Bend the two projections (tabs) at the same time upward until a dime fits snugly between the bottom of the valve stem "C" and the top of the valve lifter "D" (Fig. 11).

If liquid continues to flow when the trigger is released, grasp the valve lifter close to the handle and bend the two projections downward until a dime fits snugly between the bottom of the valve stem and the top of the valve lifter.

DISPENSING SYSTEM MUST BE THOROUGHLY CLEANED IMMEDIATELY AFTER EACH USE. DO NOT STORE LIQUID IN DISPENSER.

Remove dispenser from unit and empty. Rinse thoroughly with warm water. The dispensing system must be flushed immediately after use. Partially fill dispenser with warm water, mount on unit and then dispense all the water into a receptacle placed under the unit.

BRUSHES

ELECTRIC CORD PLUG SHOULD ALWAYS BE DISCONNECTED FROM THE ELECTRICAL OUTLET BEFORE ATTACHING, REMOVING OR CHANGING BRUSHES.

1. Lay the polisher flat exposing the underside of the unit (Fig. 12). Using a rotating motion push the brush on the spindle as far as it will go.
2. After each use remove brushes with a slight pull.
3. Wash in warm soapy water after each use. Shake out excess water. Stand bristles on paper towel to dry.

DO NOT USE HOT WATER.
DO NOT FORCE DRYING BY USING AN OVEN OR RADIATOR HEAT.

4. Remove brushes from the machine when not in use to extend the life of the brush.

PADS

ELECTRIC CORD PLUG SHOULD ALWAYS BE DISCONNECTED FROM THE ELECTRICAL OUTLET BEFORE ATTACHING, REMOVING OR CHANGING PADS.

1. To attach pads on Shampooer / Polisher: push the ends of the adapters (provided in the hardware package) through the holes in the pads, then snap adapters on to the Scrubbing Brushes. DO NOT attach to Shampoo Brushes.

2. Pads may be cleaned if desired in warm soapy water. Rinse thoroughly. Stretch out to shape and allow to dry.

HARD SURFACE FLOOR CARE

(VINYL, LINOLEUM, ASPHALT TILE AND NO WAX FLOOR)

I. SCRUBBING (FLOOR STRIPPING AND CLEANING) DISCONNECT CORD FROM ELECTRICAL OUTLET DO NOT USE MACHINE TO SCRUB WOOD FLOORS.

Attach scrubbing brushes (for scrubbing floors with an irregular surface) or nylon scrubbing pads (for scrubbing floors with a smooth surface).

Remove dispenser tank and fill with , a stripper and cleaner, diluted as indicated on container. It is recommended to put the water in first to avoid foaming.

Do not overfill tank. Allow at least one inch air space to avoid spilling.

Attach dispenser.

Plug cord into electrical outlet.

Lower handle into operating position. Turn switch to proper speed as indicated on the switch box label.

Clean floor using small circular strokes, dispensing liquid as needed.

Do not dispense liquid close to the baseboards to avoid splashing walls.

Wipe up suds with a sponge or cloth. Disconnect appliance. Remove and wash pads and brushes.

II. RENEWING THE FINISH

To renew the finish of your just cleaned floors, you may use a protective floor finish.

III. PERIODIC MAINTENANCE

Sweep or vacuum floor frequently. Damp mop weekly.

NOTE: NYLON PADS (#53871) AND BUFFING PADS (#53471) NOT INCLUDED REFER TO PAGE 12, TO ORDER

OPERATION INSTRUCTIONS

WOOD FLOORS CARE

Be sure to consult floor manufacturer for proper maintenance.

Never use **water-based** products on wood floors. Only use **solvent based** product on wood floors.

I. CLEANING

Follow instructions on wood floor cleaner found on Sears Wood Floor Care Kit, or similar product.

II. WAXING

Follow instructions on wood floor wax found on Sears Wood Floor Care Kit, or similar product.

III. POLISHING

DISCONNECT CORD FROM ELECTRICAL OUTLET.

Attach the tan polishing pads.

Make sure wax is dry before polishing. Plug cord into electrical outlet.

Lower handle into operating position. Turn appliance on.

Guide unit forward and backwards strokes, following the direction of the grain until the desired finish is achieved.

Do not apply pressure, the weight of the machine is sufficient.

Disconnect appliance, remove and wash pads.

IV. BUFFING

DISCONNECT CORD FROM ELECTRICAL OUTLET.

Attach the felt buffing pads* or the lambs wool high luster pads.

Plug cord into electrical outlet. Lower handle into operating position. Buffing will leave your floors truly lustrous.

Disconnect appliance, remove and wash pads.

V. PERIODIC MAINTENANCE

Sweep, dust or vacuum floor regularly.

Buff floors as needed, following the directions above.

To remove scuff marks on heavy traffic areas, follow the polishing directions above.

Polishing and buffing floors often will prolong the time between waxing.

CARPET CARE

SHAMPOOING

DISCONNECT CORD FROM ELECTRICAL OUTLET.

Attach the shampoo brushes.

Vacuum the carpet first to remove any loose dirt.

Remove the furniture from room, or protect its legs with a heavy plastic or aluminum foil.

Test the color fastness of your carpet by applying a small undiluted amount of shampoo directly to the carpet with a sponge on a small hidden area. If the color holds, you can proceed to shampoo the rest of your carpet.

Remove dispenser tank and fill with a carpet shampoo, diluted as indicated on the container it is recommended to put the water in first to avoid foaming.

Do not overfill the tank. Allow at least one inch air space to avoid spilling.

Attach dispenser.

Plug cord into electrical outlet. Lower handle into operating position. Turn switch to proper speed as indicated on the switch box label. Clean small areas of 3 X 3 feet at a time using small, circular and overlapping strokes. Dispense liquid until a small uniform film of foam appears.

AVOID SOAKING. Mildewing or discolorations may occur.

Continue to shampoo until the foam disappears, then proceed to another area.

Do not apply pressure. Light contact with the rug is sufficient for thorough cleaning.

When shampooing a large area, the container may need to be refilled. Always unplug the shampooer and remove the dispenser before refilling. At this time it may be convenient to check the brushes and remove any carpet fibers with a comb.

After shampooing, disconnect cord from electrical outlet. Remove and wash brushes, and flush the dispensing system.

Allow carpeting to dry thoroughly, preferably overnight. Ventilating the room or using a fan may reduce drying time. If you need to walk over wet carpet, protect it with a white cloth or towel.

Vacuum carpet to remove any dirt freed by shampooing.

REPAIR PARTS LIST FOR KENMORE FLOOR POLISHER

MODEL 680 84973 • EXTERNAL MACHINE PARTS

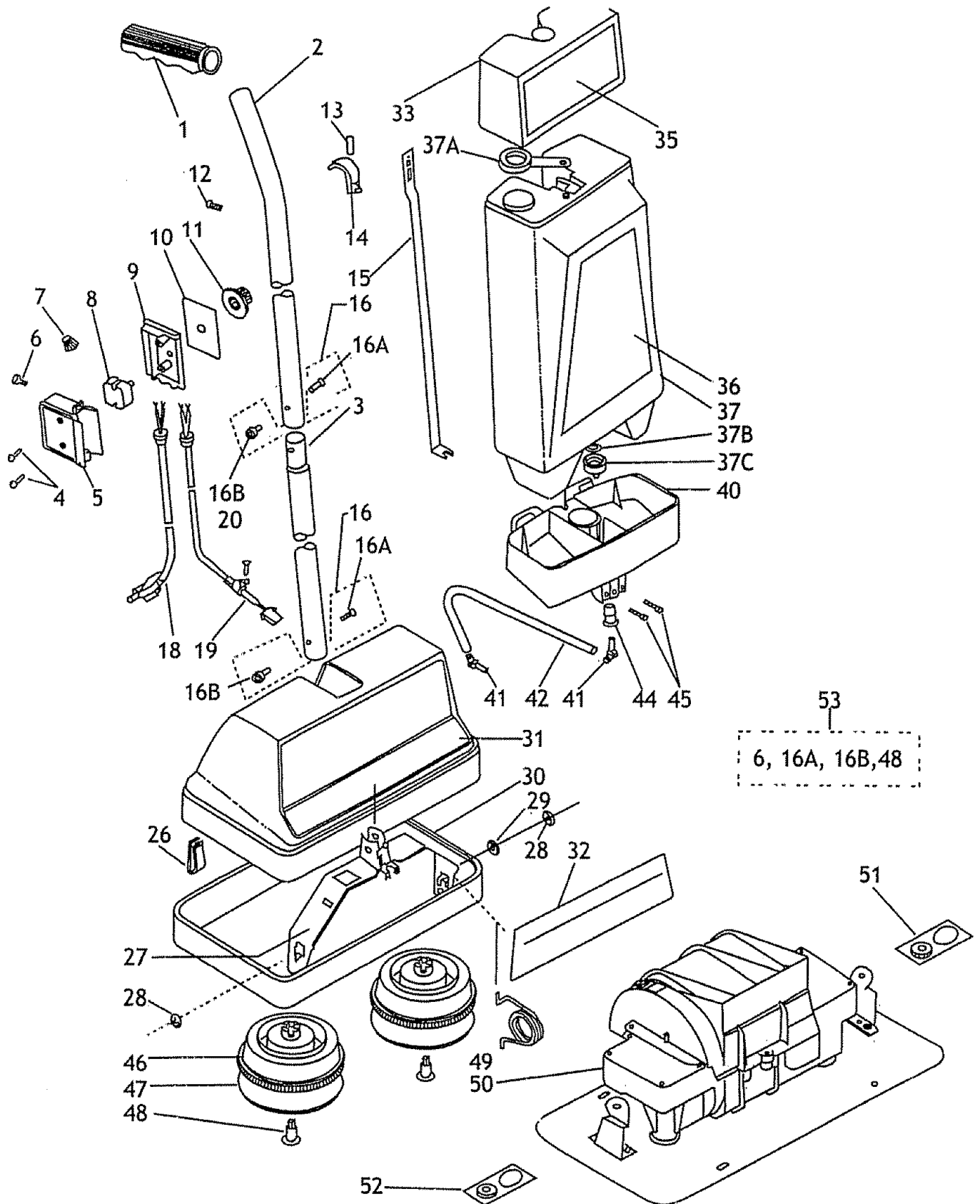

REPAIR PARTS LIST FOR KENMORE FLOOR POLISHER

MODEL 680 84973 • EXTERNAL MACHINE PARTS

KEY	PART NO.	PART NAME	KEY	PART NO.	PART NAME
1	130947	Handle	47	53471	Felt Buffing Pad (2 req.)
2	052696	Upper Handle Tube	48	130141	Pad Retainer (2 req.)
3	052710	Lower Handle Tube	48	450268	Pad Retainer 4 Pc. (Hardware Pks.)
4	010536	Self Tapping Screw 6-20 x 3/4 (2 req.)	49	240244	Spring Yoke Torsion (1 req.)
5	130950	Switch box	50	491899	Motor Assembly 3 speed
6	010154	Self Tapping Screw 6-20 x 5/16	51	461717	Replacement Gear and Grease L
7	100042	Wire Nut	52	461718	Replacement Gear and Grease R
8	110083	Switch 3 speed	53	461675	Hardware Pks.
9	130951	Switch Box Cover	54	191506	Manual
10	171724	Box Label 3 Speed			
11	130952	Switch Knob			
12	010273	Self Tapping Screw 6-20 5/8			
13	240091	Valve Spring			
14	131062	Dispenser Trigger			
15	051721	Dispenser Rod			
16	450330	Handle Screw and Nut Pkg. (2 req.)			
16 A	010747	Screw 10-32 x 1 1/4 (2 req.)			
16 B	020067	Nut (2 req.)			
18	100099	Line Cord			
19	280432	Motor Cable Assy			
20	010063	Self Tapping Screw 6-20 x 1/2			
26	052692	Clip			
27	462112	Yoke Socket Assembly			
28	040444	Yoke Retainer (2 req.)			
29	130715	Spacing Washer			
30	120457	Furniture Guard			
31	130374	Cover (Chrome)			
32	174439	Head Label			
33	131650	Container Top			
35	174437	Container Top Label			
36	174438	Tank Label			
37	450169	144 Oz. Tank Assy			
37 A	130064	Tank Cap			
37 B	040136	Rubber Washer			
37 C	130068	Valve Cover			
40	130948	Container Base			
41	130065	Elbow Hose Connector (2 req.)			
42	130071	Hose			
44	120694	Container Base Seal			
45	011093	Self Tapping Screw 8 x 3/8 (2 req.)			
46	53271	Scrub Brush (2 req.)			
46	53071	Shampoo Brush (2 req.)			
47	53971	Tam Polishing Pad (2 req.)			
47	53671	Lambswool High Luster Pad (2 req.)			
47	53871	Nylon Scrubbing Pad (2 req.)			

ACCESSORIES INCLUDED

53071	Shampoo Brushes (1 pair)
53271	Scrubbing Brushes (1 pair)
53671	Lambswool Pads (1 pair)
53971	Polishing Pads (1 pair)

REPLACEMENT PARTS:
WHEN SERVICING USE ONLY IDENTICAL REPLACEMENT PARTS. REPLACE DAMAGE CORDS.

NOTE:
FOR INSTRUCTIONS ON "HOW TO ORDER REPAIR PARTS" SEE PAGE 12.

REPAIR PARTS LIST FOR KENMORE FLOOR POLISHER

MODEL 680 84973 • INTERNAL MACHINE PARTS

KEY	PART NO.	PART NAME	KEY	PART NO.	PART NAME
60	131418	Motor Cover	98	010154	Self Tapping Screw 6 x 5/16 (2 req.)
61	011483	Self Tapping Screw	99	010066	Self Tapping Screw 6 x 7/8 (1 req.)
62	280324	Brush Holder Assy	101	251063	Push Plate 0.005"
62 A	460104	Brush	102	462069	Grease (2 req.)
62 B	460590	Holder Assy			
63	280263	Armature			
64	011489	Self Tapping Screw 8-18 x 1/2 (4 req.)			
65	054244	Field Support (2 req.)			
67	280267	Field 3 Speed			
67 A	081832	Field Sleeve			
68	011490	Self Tapping Screw 8 x 5/16 (2 req.)			
69	050607	Bearing Clamp (2 req.)			
70	120133	Bearing Armature Seal (2 req.)			
71	260026	Armature Bearing (2 req.)			
72	260001	Thrust Ball (2 req.)			
73	250059	Push Plate 0.050"			
74	250060	Push Plate 0.010"			
75	100055	Connector Block 3 Speed			
76	020016	3/8" Hex. Nut (2 req.)			
77	420011	Bronze Gear R			
78	420012	Bronze Gear L			
79	251024	Spindle (2 req.)			
80	250988	Spindle Key (2 req.)			
81	040018	Washer (4 req.)			
82	040238	Spindle Retainer (2 req.)			
83	131956	Frame Insulator (2 req.)			
84	230462	Gear Case Cover Conmutator (1 req.)			
85	230461	Gear Case Cover Fan (1 req.)			
86	370133	Gasket (2 req.)			
87	051119	Connector Support			
88	23-0330-3	Motor Frame Assy			
89	130059	Frame Spacer			
90	131040	Motor Support (3 req.)			
91	130758	Base Insulator			
92	230499	Base Plate Assembly			
93	011489	Self Tapping Screw (7 req.)			
94	130551	Screw Insulator (3 req.)			
95	131212	Tray			
96	461610	Spindle Cap Insulator Pkg. (2 req.)			
96 A	131038	Cap Insulator (2 req.)			
96 B	240225	Spring (2 req.)			
96 C	131039	Key (2 req.)			
96 D	251298	Pin (2 req.)			
96 E	131135	Insulator (2 req.)			
97	040002	Washer			

REPLACEMENT PARTS:

WHEN SERVICING USE ONLY IDENTICAL REPLACEMENT PARTS. REPLACE DAMAGE CORDS.

NOTE:

FOR INSTRUCTIONS ON "HOW TO ORDER REPAIR PARTS" SEE PAGE 12.



The Service Side of Sears.™

**Model No.
680.84973**

For the repair or replacement parts you need

Call 7 am- 7pm, 7 days a week

1-800-366-PART

(1-800-366-7278)

For in-home major brand repair service

Call 24 hours a day, 7 days a week

1-800-4-MY-HOMESM

(1-800-469-4663)

For the location of a Sears Parts and Service Center in your area

Call 24 hours a day, 7 days a week

1-800-488-1222

(1-800-469-4663)

**For more information on purchasing a Sears Maintenance Agreement
or to inquire about an existing Agreement**

Call 9 am - 5 pm, Monday-Saturday

1-800-827-6655

Your Sears Merchandise has added value when you consider that Sears has service units nationwide staffed with Sears trained technicians... Professional technicians specially trained on Sears products, having the parts, tool and the equipment to insure that we meet our pledge to you... We service what we sell.

Model/Serial

Number: _____

Model and Serial Number may be found on the number plate on the
BOTTOM OF THE SHAMPOOER/POLISHER

You should record both Model and Serial Number and keep in a safe place for future reference.

